

Thank you for purchasing the Wouxun KG-1000M mobile MURS radio.

Your feedback makes our products better. Please share your thoughts.

[feedback@buytwowayradios.com](mailto:feedback@buytwowayradios.com)

[www.buytwowayradios.com](http://www.buytwowayradios.com)

## Contents

<b>Safety Information</b> .....	<b>8</b>
FCC Licensing Information.....	12
<b>Installation and Setup</b> .....	<b>13</b>
What's Included .....	13
Transceiver Installation.....	14
Connecting a Power Source.....	16
Replacing the Fuse.....	17
Connecting an Antenna.....	18
Front Panel Installation .....	20
External Speakers .....	25
Hand Microphone Installation.....	26
<b>Getting Started</b> .....	<b>27</b>
Feature Summary.....	27
Front Panel Guide .....	29

LCD Guide .....	30
Back Panel .....	31
Side Panels.....	31
Hand Microphone .....	32
<b>Basic Operation .....</b>	<b>33</b>
Introducing MURS and the KG-1000M .....	33
Your First Transmit.....	34
Dual Display: Using Areas “A” and “B” .....	36
Frequency and Channel Modes .....	37
NOAA Weather Mode.....	39
Hand Microphone Hotkeys .....	40
<b>Menu Functions .....</b>	<b>48</b>
[1: STEP] Frequency Step.....	48
[2: W/N] Bandwidth .....	48



[3: MPOWSET] Medium Power Level.....	48
[4: ROGER] Roger Beep .....	49
[5: BEEP] Button Beeps.....	49
[6: VOICE] Voice Guide.....	49
[7: BCL] Busy Channel Lockout .....	50
[8: SP-MUTE] Speaker Mute Settings .....	50
[9: SC-REV] Scan Method.....	50
[10: TOT] Transmit Overtime Timer .....	51
[11: TOA] Transmit Overtime Alarm .....	52
[12: ANI-SW] Caller ID Transmit.....	52
[13: RING] DTMF Prompt Time .....	52
[14: ANI-EDIT] Caller ID Edit.....	53
[15: DTMFST] Sidetone .....	53
[16: PTT-ID] Caller ID Transmit Position .....	53

[17: TX-LED] Transmit LED Color .....	54
[18: WT-LED] Standby LED Color .....	54
[19: RX-LED] Receive LED Color .....	54
[20: DEL-CH] Channel Delete.....	55
[21: CH-NAME] Channel Name Edit .....	55
[22: PRICH-SW] Priority Channel On/Off .....	56
[23: SPK-CONT] Speaker Select .....	56
[24: AUTOLOCK] Auto Lock .....	57
[25: RX-CTC] Receive CTCSS Tone.....	57
[26: RX-DCS] Receive DCS Tone .....	57
[27: TX-CTC] Transmit CTCSS Tone.....	58
[28: TX-DCS] Transmit DCS Tone .....	58
[29: SCAN-ADD] Channel Scan Add / Delete .....	58
[30: APO-TIME] Power Off Timer .....	59



[31: ALERT] Single Tone Pulse Transmission .....	59
[32: COMPAND] Comander .....	60
[33: FAN-SET] Cooling Fan Settings .....	60
[34: LOW-V] Low Voltage Alert.....	60
[35: SCRAM] Descramble .....	61
[36: SC-QT] CTCSS/DCS Scan Save Options .....	61
[37: SC-CTC] CTCSS Tone Scanning .....	62
[38: SC-DCS] DCS Tone Scanning .....	62
[39: SC-GROUP] Scan Group .....	63
[40: RPT-TONE] Repeater Reception Confirmation .....	63
[41: RESET] Factory Reset.....	64
[42: KEY-A] Key “A” Assignment .....	64
[43: KEY-B] Key “B” Assignment .....	64
[44: KEY-C] Key “C” Assignment .....	65

[45: ABR] Backlight.....	65
[46: FM-RADIO] FM Radio .....	66
[47: AUT. AM] AM Detection .....	66
[48: AM-SW] AM On / Off .....	66
<b>Advanced Operation .....</b>	<b>68</b>
DTMF Encoding .....	68
Setting Non-Standard CTCSS or DCS .....	69
<b>Troubleshooting .....</b>	<b>72</b>
<b>Technical Information .....</b>	<b>74</b>
Specifications .....	74
Standard CTCSS and DCS Tones .....	75
Default MURS Channels and Frequencies.....	77
<b>Optional Accessories.....</b>	<b>79</b>
<b>Limited Warranty .....</b>	<b>80</b>

## Safety Information

The KG-1000M is an electrical apparatus, as well as a generator of RF (Radio Frequency) energy, and you should exercise all safety precautions as are appropriate for this type of device. These safety tips apply to any device installed in a well-designed radio station.

- ⚠ Explosive atmospheres (gases, dust, fumes, etc.). Turn OFF your mobile radio while taking on fuel or while parked in gasoline service stations. Do not carry spare fuel containers in the trunk of your vehicle if your mobile radio is mounted in the trunk area.
- ⚠ Injury from radio frequency transmissions. Do not operate your mobile radio when somebody is either standing near to or touching the antenna, to avoid the possibility of radio frequency burns or related physical injury.
- ⚠ Dynamite blasting caps. Operating the mobile radio within 150m (500 feet) of dynamite blasting caps may cause them to explode. Turn OFF your mobile radio when in areas where blasting is in progress, or where “TURN OFF TWO-WAY RADIO” signs have been posted. If you are transporting blasting caps in your vehicle, make sure they are carried in a closed metal box with a padded interior. Do not transmit while the caps are being placed into or removed from the container.



- ⚠ Never allow unsupervised children to play in the vicinity of your mobile radio or antenna installation.
- ⚠ Be certain to wrap any wire or cable splices thoroughly with insulating electrical tape, to prevent short circuits.
- ⚠ Do not route cables or wires through door jambs or other locations where, through wear and tear, they may become frayed and shorted to ground or to each other.
- ⚠ Do not stand in front of a directional antenna while you are transmitting into that antenna. Do not install a directional antenna in any location where humans or pets may be walking in the main directional lobe of the antenna's radiation pattern.
- ⚠ In mobile installations, it is preferable to mount your antenna on top of the roof of the vehicle, if feasible, so as to utilize the car body as a counterpoise for the antenna and raise the radiation pattern as far away from passengers as possible.
- ⚠ During vehicular operation when stopped (in a parking lot, for example), make it a practice to switch to Low power if there are people walking nearby.

## Safety Information

- ⚠ Never wear dual-earmuff headphones while driving a vehicle.
- ⚠ Do not attempt to drive your vehicle while entering frequencies or accessing menu items using the DTMF microphone, front panel or the base unit. Pull over to the side of the road and put the vehicle in park before adjusting or programming the transceiver.

### Notice

- These tips are important for safe operation of your KG-1000M mobile radio and its accessories. If they do not function normally, please get in touch with your dealer immediately.
- If you use components or accessories not produced by the Wouxun Company, Wouxun will not guarantee the safety and usability of the transceiver.

### Caution

Please read this manual before using, as it includes important instructions for the safe handling, use and operation of your radio.

### FCC Compliance

This device complies with Part 15 of the FCC Rules. Operation is subject to the following two conditions:

- (1) This device may not cause harmful interference, and
- (2) This device must accept any interference received, including interference that may cause undesired operation.

**WARNING: MODIFICATION OF THIS DEVICE TO RECEIVE CELLULAR RADIOTELEPHONE SERVICE SIGNALS IS PROHIBITED UNDER FCC RULES AND US FEDERAL LAW.**

## **Safety Information**

### **Radio Operation and EME Exposure**

Use only an antenna designed for use with this radio and its operating frequencies. Unauthorized modifications or attachments may damage the radio and violate FCC rules.

DO NOT hold the antenna while the radio is in use.

DO NOT attempt to use the radio with a damaged antenna or feed line.

### **FCC Licensing Information**

The Wouxun KG-1000M is FCC Part 95J type accepted for use on MURS. The KG-1000M operates on Multi-Use Radio Service (MURS) frequencies according to the Federal Communications Commission (FCC) Rules in the United States. MURS is licensed by rule for business or personal use. As such, an individual MURS license is not required to transmit on these frequencies. For more information, visit the FCC's web site at [fcc.gov](http://fcc.gov).

## What's Included

Carefully unpack the contents of the box and be sure that you have the items in the list below. If any items are missing, please contact your dealer.



Mobile/Base  
Transceiver



Hand  
Microphone

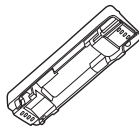

Inclined Switchboard  
Panel (Already Installed  
on Mobile Transceiver)

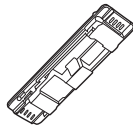

Flat Switchboard  
Panel



Screw Sets

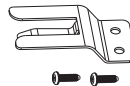

Hand  
Microphone  
Hook

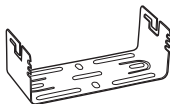

Mobile Mounting  
Bracket

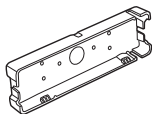

Remote Front  
Panel Bracket



Mobile Power  
Cord

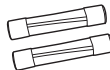

Fuse



Extension  
Cable



User Manual

## Installation and Setup

### Transceiver Installation

Choose a safe place inside your vehicle to install the transceiver, considering a location that would not cause harm to passengers while the vehicle is in motion or in case of an accident or sudden braking. Install the transceiver in an area with good ventilation and away from direct exposure to the sun.

1. Use the supplied self-tapping screws to install the support bracket in the vehicle.
2. Set the transceiver in the bracket, then insert the supplied combined screws and tighten, ensuring that the screws are fastened tightly. This will ensure the support bracket and the transceiver do not become loose when the vehicle hits bumps or shakes.

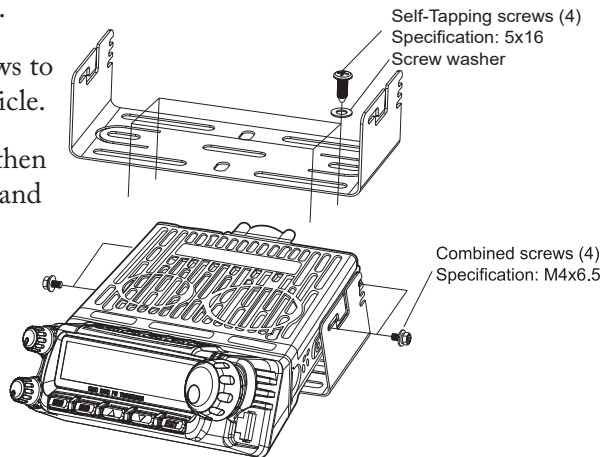

3. Several screw slots are provided along the side of the support bracket to allow for installing the transceiver at different angles.

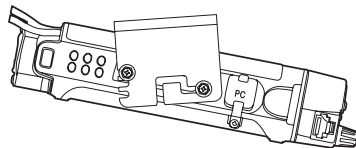
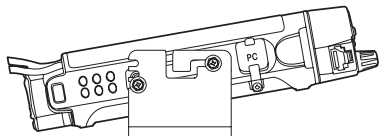
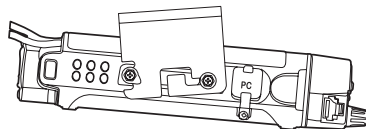
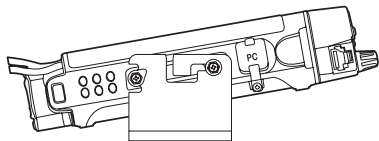
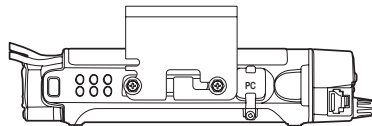
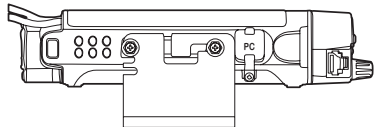

## Installation and Setup

### Connecting a Power Source

The power requirement of the transceiver ranges from  $13.8\text{V}\pm 15\%$ . If the power source exceeds  $16\text{V}$ , TX will be disabled but RX will operate as normal. If the power source falls below  $11.5\text{V}$ , the transceiver will automatically shut off to prevent it from draining the battery and affecting the normal operation of the vehicle. (See menu option 34.)

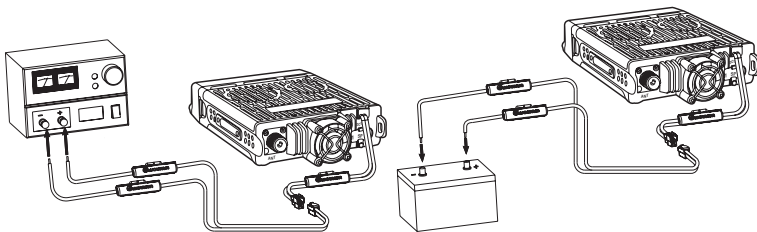

### Important

The transceiver's operating voltage is  $13.8\text{V}\pm 15\%$  DC.



## Replacing the Fuse

In the event that the transceiver blows a fuse, first determine the cause, then replace the fuse. If after installing the new fuse it blows again, disconnect the power source immediately and contact your authorized Wouxun dealer for assistance.

The specified fuse current is 15A. The specified power source current is 20A and above.

Refer to the following diagram for fuse installation. Be sure the fuse is properly seated and secured to the copper set.

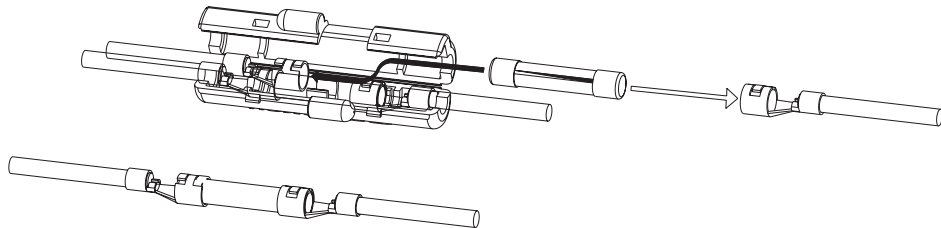

## Installation and Setup

### Connecting an Antenna

Before using the transceiver, you must correctly connect a properly tuned and installed antenna. To get the best results, be sure the antenna is tuned for the frequencies that you intend to use, and the antenna's impedance is 50 ohms. **Using an incorrect or improperly installed antenna could harm the transceiver. Never attempt to transmit without an antenna connected!**

The transceiver is equipped with an SO-239 (UHF female) antenna connector. It will require an antenna cable with a PL-259 (UHF male) connector.

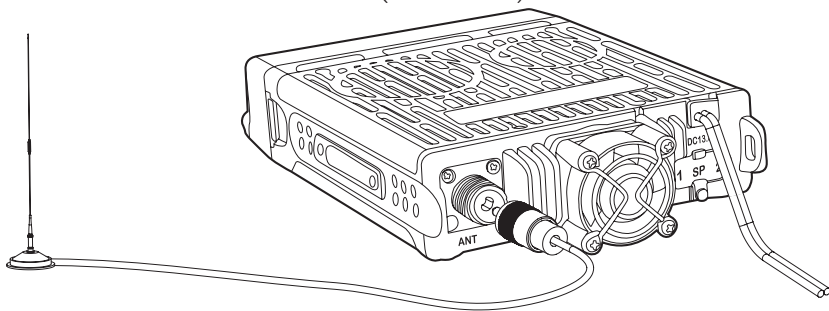

The highest point of any MURS station antenna must not be more than 18.3 meters (60 feet) above the ground or 6.10 meters (20 feet) above the highest point of the structure on which it is mounted. MURS station antennas must also meet the requirements in §95.317 regarding menaces to air navigation. See 47 CFR 95.317 and consult part 17 of the FCC's Rules for more information (47 CFR part 17).

### Important

MURS is limited to 2 watts of power. Antenna gain should not have the effect of raising power above the 2 watt legal limit.

## Installation and Setup

### Front Panel Installation

The transceiver includes two switchboard panels for the front display: an angled panel for an inclined display, and a flat panel for a traditional display. The angled panel is installed by default.

#### Install Inclined Switchboard Panel

1. Align switchboard with front panel.

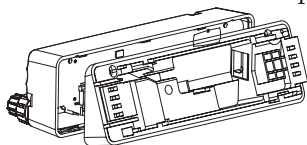

2. Insert tabs into base of front panel

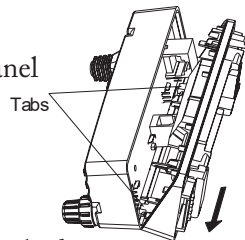

3. Close switchboard as shown

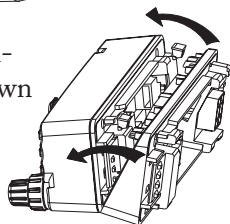

4. Fasten using supplied screws  
Self-Tapping screws  
Specification: 2x16

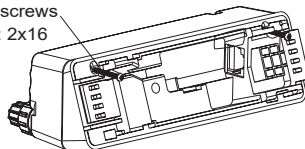

### Install Flat Switchboard Panel

1. Align switchboard with front panel.
2. Insert tabs into base of front panel

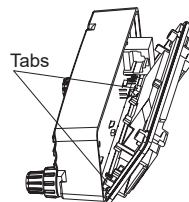
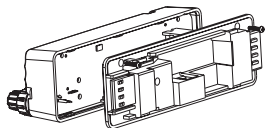

3. Close switchboard as shown

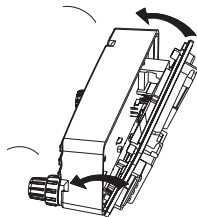

4. Fasten using supplied screws

Self-Tapping screws (2)  
Specification: 2x11

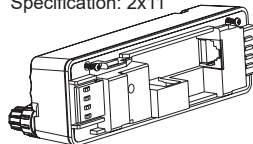

## Installation and Setup

### Connecting Front Panel to Transceiver

1. Connect the 8-pin front panel cable to both the transceiver and the front panel.

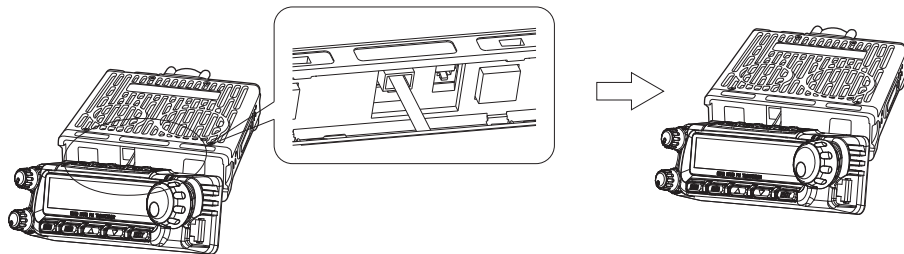

2. With the front panel slightly off-center to the right, hold the front panel flush with the transceiver and slide to the left to lock into place.

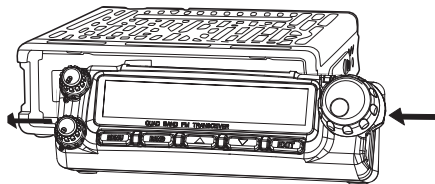

### Removing Front Panel from Transceiver

1. Press and hold the tab on the right side of the switchboard / front panel while sliding the front panel in the direction of the arrow.

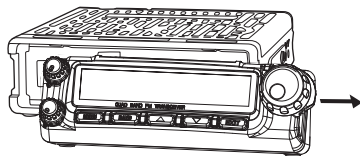

### Front Panel to Transceiver Cable Specifications

The cable connecting the front panel to the transceiver uses 8-pin RJ-45 type connectors. A short cable is provided for installations where the front panel will be attached to the transceiver. A longer extension cable is also included for use in installations where the front panel will be mounted detached from the transceiver.

**Please note, a standard ethernet cable cannot be used as a replacement for this cable. This cable requires that pins 2 and 4 be reversed on one of the connectors.**

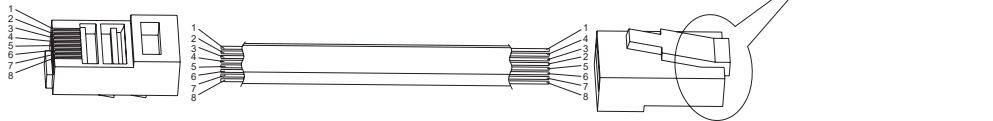

## Installation and Setup

### Installing the Front Panel Support Bracket

The front panel can be installed detached from the transceiver body. This allows for considerable flexibility when considering where to install the KG-1000M. For an installation with a detached front panel, you will use the included support bracket.

1. Secure the support bracket using the supplied screws. Be sure to leave room for the front panel extension cable to be inserted through the back.

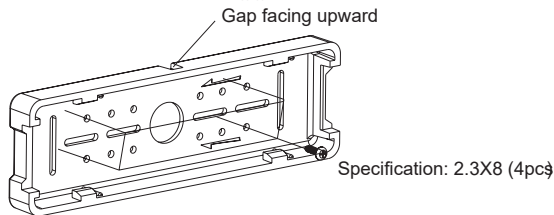

2. Feed the extension cable through the center of the support bracket, then connect to the front panel. Attach front panel to support bracket as shown.

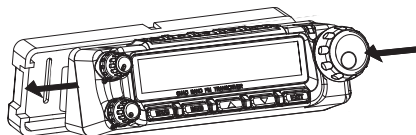
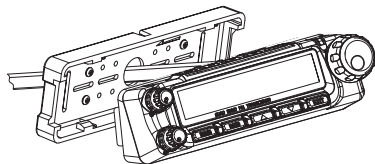



## External Speakers

The KG-1000M is equipped with two 3.5mm external speaker jacks on the back of the transceiver. Connecting speakers to one or both of these ports will direct audio to the external speaker instead of the speaker inside the radio body.

The sound from areas “A” and “B” are output separately, allowing you to install a different speaker for each area. The rubber speaker port cover has labels embedded over each port. The port labeled “1” corresponds to the audio output for Area “A” and the port labeled “2” corresponds to Area “B”.

To have all audio directed to a single external speaker, a 3.5mm Y-adapter is required. The Y adapter will need two 3.5mm male connectors and one 3.5mm female connector.

The radio must be powered off/on after external speakers are connected before they will become active.

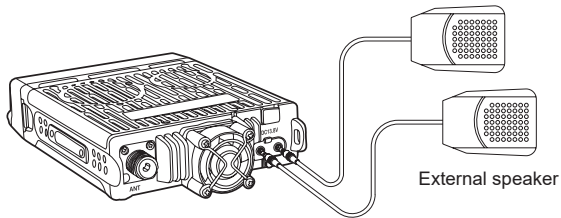

## Installation and Setup

### Hand Microphone Installation

To connect the included hand microphone to the transceiver, plug the microphone into the port on the right side of the front panel.

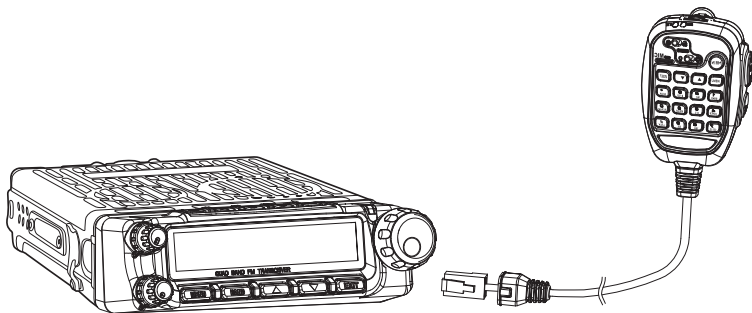

### Feature Summary

- 5 MURS Channels
- Up to 2W Output Power
- Built-in NOAA Weather Channels
- FM Radio Mode
- Simultaneous Dual Mode Operation
- Simultaneous Reception
- Tune Specific Frequencies Directly (Frequency Mode)
- Large LCD Dual Frequency Display
- Three Color Selectable LED
- Up to 999 Custom Channels
- Remote Front Panel Mounting
- PC Programming Software Support
- 4 TX Power Levels (L/M1/M2/H)
- Wide Receive (RX) Frequency Range:
  - 50-53.995 & 108-179.995 MHz
  - 320-349.995 & 400-479.995 MHz
  - 700-985 MHz
- Transmit (TX) Frequencies:
  - 154.570MHz (MURS Channel 1)
  - 154.600MHz (MURS Channel 2)
  - 151.820MHz (MURS Channel 3)
  - 151.880MHz (MURS Channel 4)
  - 151.940MHz (MURS Channel 5)
- Standard and Non-Std CTCSS/DCS
- Split CTCSS/DCS Tone Support
- CTCSS/DCS Tone Scan
- Wide/Narrow Bandwidth Selectable

## Getting Started

- DTMF Hand Microphone with Speaker, TX/RX Indicator and Volume Control
- 3 Configurable Front Panel Buttons
- Comander
- Descrambler (8 Groups)
- APO Power Management
- English Voice Guide
- Receive AM Transmissions
- Auto-Detect AM Transmissions
- Single Tone Pulse Frequency
- Minimum Operating Voltage Settings
- Adjustable Cooling Fan Control
- Automatic Temperature Testing
- Scan with CTCSS / DCS Detection
- Simultaneous Scanning on A/B Areas
- Priority Channel Scanning
- Supports 10 Scan Groups
- Dual Speakers
- Multiple Speaker Output Settings
- External Speaker Support
- DTMF Encoding & Decoding
- Incoming Caller ID Display
- Group Call, All Call and Selective Call

## Front Panel Guide

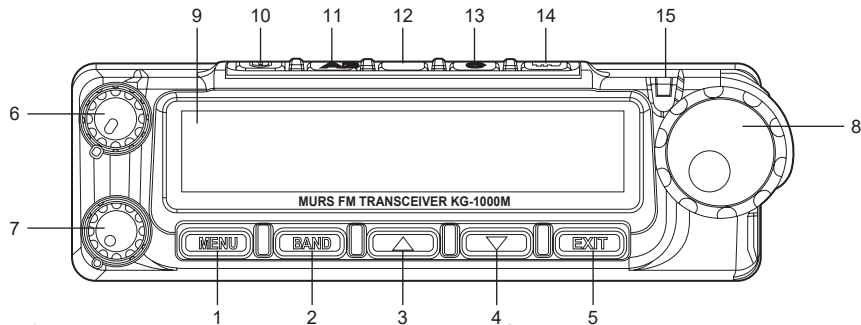

1. Menu / Enter Key
2. A/B Area Switch / Weather Mode
3. Up Key
4. Down Key
5. Exit / Cancel Key
6. "A" Area Volume Control
7. "B" Area Volume Control
8. Frequency / Channel Knob
9. LCD
10. On / Off Button
11. Configurable Hotkey "A" (Page 64)
12. Configurable Hotkey "B" (Page 64)
13. Configurable Hotkey "C" (Page 65)
14. Keypad Lock Button
15. Status Indicator Light

### LCD Guide

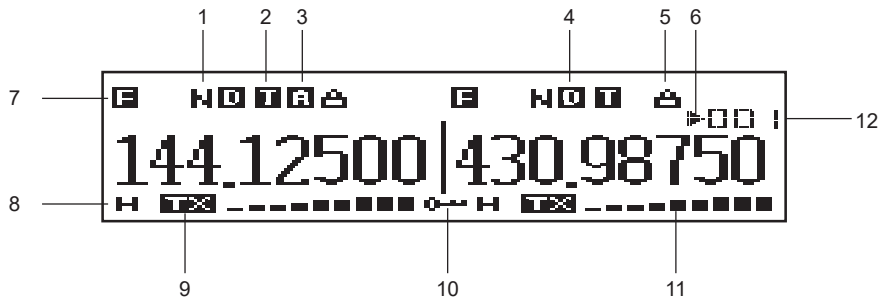

- |                                      |                                       |
|--------------------------------------|---------------------------------------|
| 1. Bandwidth Indicator (Wide/Narrow) | 7. Menu Setting Mode Indicator        |
| 2. DTMF Mute                         | 8. TX Power Indicator (L/M/H)         |
| 3. AM Mode Indicator                 | 9. Transmit/Receive Indicator (RX/TX) |
| 4. DCS/CTCSS Indicator (D/C)         | 10. Keypad Lock Indicator             |
| 5. Descramble Indicator              | 11. Signal Strength Indicator         |
| 6. Priority Channel Indicator        | 12. Channel Number/Menu Item          |

## Back Panel

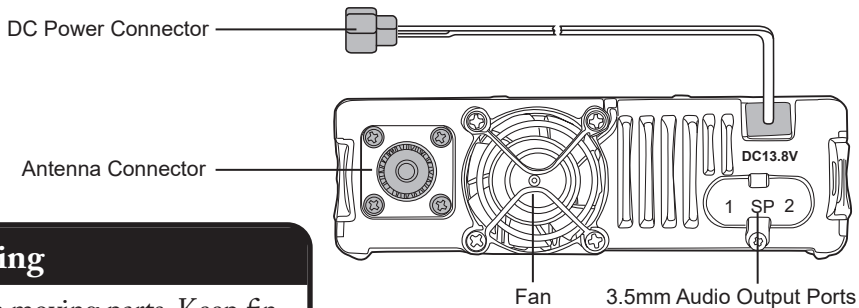

### Warning

Fan has moving parts. Keep fingers and other body parts away.

## Side Panels

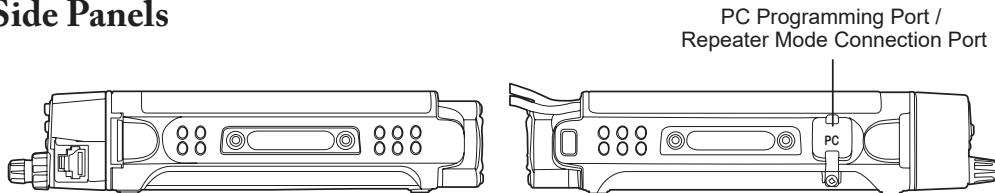

## Hand Microphone

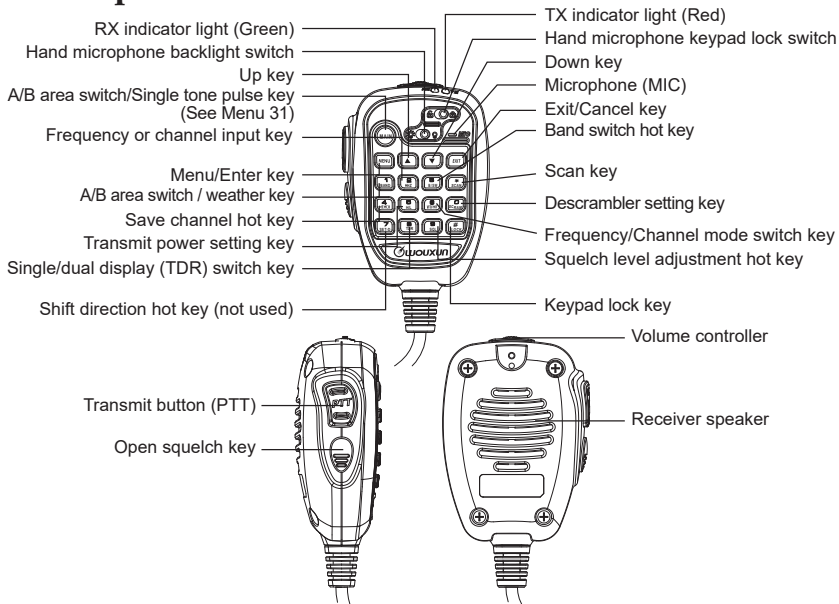



## Introducing MURS and the KG-1000M

The Multi-Use Radio Service (MURS) is a two way radio service that offers some powerful benefits. MURS frequencies are located in the VHF band, which tends to perform well in outdoor environments. Users are allowed to transmit at up to 2 watts of power and connect removable or external antennas for extended range. MURS does not require the user to purchase a license, as the service is licensed by rule for business, industrial, recreational or personal use.

The KG-1000M was designed to allow you to take advantage of all that MURS has to offer and more. Right out of the box this radio is configured to allow you to transmit on the 5 license-free MURS simplex channels. NOAA weather mode is available at the touch of a button, as well as an FM radio.

Read this chapter to learn the basics of using your new KG-1000M radio, such as selecting a channel, transmitting and receiving, using the dual display, scanning, and using frequency mode. Before continuing, be sure your radio is powered on and connected to an antenna!

### Your First Transmit

#### Selecting a Channel

When you power on your KG-1000M for the first time, the display will likely show “MURS-01” on the left side. MURS-01 is the name of the currently selected channel. Turn the Frequency / Channel Knob on the right side of the display to navigate through the list of channels.

As a license-free MURS user you are allowed to use any of the channels. The channel you choose isn't as important as making sure it's the same channel the rest of your group is using. Be sure the channel you select is also supported by the equipment everyone else in your group is using.

The rules for MURS are the same for all channels, with one exception concerning bandwidth. MURS channels can be broken up into 2 groups, with the following difference:

- Channels 1-2 support 20.00 kHz wideband and 11.25 kHz narrowband operation.
- Channels 3-5 are limited to a maximum 11.25 kHz narrowband operation.

### Transmitting and Receiving

With a channel selected, the radio is actively “listening” for an incoming signal on that channel. When a signal is detected, the transmission will be heard through the radio’s speaker. Please note, the Squelch setting (page 44) determines how strong a signal needs to be in order to be detected.

To transmit, first be sure the channel is clear and then hold the hand microphone a few inches from your mouth. Hold down the PTT button on the side of the microphone while talking and release the PTT when finished.

### Dual Display: Using Areas “A” and “B”

The KG-1000M is two radios in one! The dual display function allows you to monitor two channels at the same time. While this may sound complex, the KG-1000M is designed to make this powerful feature easy to use.

The display is divided in half with the left side referred to as “Area A” and the right side referred to as “Area B”. Each area controls a separate radio. A down arrow indicator above the channel/frequency display indicates which area is primary. When you perform an operation on the radio, such as changing channels or transmitting, that operation is performed on the currently active area.

### Turning the Dual Display On and Off

The dual display is off by default on the KG-1000M. Instead of a frequency or channel name, the text “KG-1000M” will be displayed in the inactive area when the dual display is off.

Use the TDR function to toggle between a single and dual display. By default, the TDR function is assigned to Hotkey “C”, but it can also be activated by pressing the number

8 key on the hand microphone (labeled TDR).

## Changing the Primary Area

With Dual Display on, press the BAND key on the front panel or the number 1 key on the hand microphone to switch the primary area. You will see the down arrow indicator above the frequency or channel move from one area to the other.

With Dual Display off, pressing the BAND key will switch the currently active area as well, but will also turn off the previously active area. For example, with Area “A” on and Area “B” off, pressing BAND would turn on Area “B” and turn off Area “A”.

## Frequency and Channel Modes

The KG-1000M supports tuning frequencies via two methods: channel and frequency modes.

In channel mode, frequencies that have been saved can be selected from the channel list. This is the default mode and is the most convenient way to access commonly used frequencies. The transceiver is pre-configured with 5 MURS channels, but allows users

## Basic Operation

to save custom channels as well (up to 999). In channel mode, turning the Channel/Frequency Knob or pressing an arrow key will tune to the next channel in the list.

Frequency mode (also referred to as VFO mode) allows you to tune directly to a specific frequency regardless of the frequency having been previously saved. In frequency mode, turning the Channel/Frequency Knob or pressing an arrow key will tune to a higher or lower frequency. The STEP menu option (page 48) allows you to adjust the step between each frequency. To enter a frequency directly, press the number 2 key on the hand microphone (labeled MHZ) and type the frequency using the keypad.

The KG-1000M supports the following frequency bands:

KG-1000M Frequency Bands	
50.000 - 53.995 MHz	108.000 - 179.995 MHz
320.000 - 349.995 MHz	400.000 - 479.995 MHz
700.000 - 985.000 MHz	

## Switching Bands in Frequency Mode

In frequency mode, tuning frequencies using the Channel/Frequency Knob or arrow keys will not automatically move from one frequency band to another. To switch to a different frequency band, press the number 8 key on the hand microphone (labeled B/SW) while in frequency mode.

## NOAA Weather Mode

NOAA Weather Mode allows you to quickly access weather information from a local NOAA broadcast station.

To activate NOAA Weather Mode, hold down the BAND key for 2 seconds. The display will change to show a NOAA broadcast station frequency starting with 162 MHz. Use the Channel/Frequency Knob or the arrow keys to navigate to your preferred NOAA station. Your most recently selected station will be remembered each time you

### Reminder

The KG-1000M will only transmit on the 5 MURS frequencies and at a maximum of 2 watts. Band and frequency support for other frequencies is provided for listening only.

## Basic Operation

enter this mode.

To locate the NOAA station closest to your location, visit the following site:

[https://www.weather.gov/nwr/station\\_listing](https://www.weather.gov/nwr/station_listing)

## Hand Microphone Hotkeys

### (1) [BAND] Primary Frequency Selection Hotkey

When the transceiver is in standby, press the [BAND] key on the handset or transceiver to switch between primary frequency and secondary frequency.

### Important!

When the A or B area of the screen displays an “▼” icon, this indicates that side is the Primary and the other area is the secondary side. This is very important, as all of the active operations will be performed on the Primary side.



## (2) [MHZ] Frequency or Channel Selection Hotkey

When the transceiver is in frequency mode, press the [MHZ] key to enter a specific frequency. Eight hyphens will appear. Enter the 6 digit frequency. The last 2 digits will be automatically entered, based on the following:

- 1. When the 6th digit is 0 or 5, then the 7th and 8th digits will be 0.
- 2. When the 6th digit is not 0 or 5, the 7th and 8th digits will be 25, 50 or 75 according to the 6.25k step frequency of the 5th digit.

If any keys other than 0-9 are pressed while entering the 6-digit frequency, it will exit the frequency setting.

In channel mode, press the [MHZ] key to tune to a specific channel number. The first digit of the current channel number will begin flashing. Enter the desired channel number using 3 digits. For example, if you would like channel 9, enter 009.

## (3) [B/SW] Band Switching Hotkey

## Basic Operation

The KG-1000M can receive signals on multiple bands and frequency ranges.

In frequency mode, press the [B/SW] key on the hand microphone to switch the current band. Area A (left side) supports all available bands. Area B (right side) has 2 selectable bands: 136-174.995 MHz and 400-479.995 MHz.

### (4) [MEMCH] Save Channel Hotkey

When in Channel mode, channel information can be saved to the specified channel with the exception of Channel Name and Channel Scan settings.

When in Frequency (VFO) mode, you can set the frequency, CTCSS tone or DCS code and other options, then save them to the specified channel.

For example, to save a GMRS receive-only channel in Frequency mode with a 462.550 receive frequency and a 67.0 receive CTCSS tone:

1. Tune to the frequency 462.550, press [MENU] + [2] + [5] to enter the Receive CTCSS setting, press [UP] / [DOWN] to select the 67.0 tone, and then press [MENU] to confirm.

2. Press [4] on the hand microphone to enter the Save Channel function, enter the channel number, then press [MENU] to confirm the setting and return to standby mode.

### **(5) [H/L] Output Power Hotkey**

When the radio is in standby, the [H/L] key toggles the power level. Every time the key is pressed, the power level changes from high, to medium, to low, then back to high again. Medium output power has two levels (See MENU 3, p 48). Note that MURS frequencies are legally limited to a maximum of 2 watts.

### **(6) [VFO/MR] Frequency/Channel Mode Hotkey**

This key toggles between Channel (MR) and Frequency (VFO) modes every time the key is pressed. Channel mode has three different channel display types: Channel Number display mode, Frequency+Channel Number display mode, and Channel Name display mode.

### **(7) [SET-D] Frequency Shift Direction Hotkey**

## Basic Operation

Not available on the KG-1000M.

### (8) [TDR] Single or Dual Display Hotkey

When in standby, press the [TDR] key to switch between single and dual display modes.

### (9) [SQL] Squelch Level Hotkey

The SQL function allows adjustment of the squelch setting. Press the [SQL] key, then press the UP / DOWN arrow keys or enter 0-9 to choose the desired squelch level. Press [MENU] to confirm, then press [EXIT] to save the setting and exit the menu.

### (0) [SCRAM] Descrambler Hotkey

The SCRAM function allows you to activate the descrambler function for the selected frequency or channel. Selecting this option prompts for the selection of a scrambling protocol (1-8), or OFF to disable the descrambler.

Please note, MURS rules do not allow for frequency scrambling. Activating this feature

is only useful when using the KG-1000M to listen to scrambled transmissions on non-MURS frequencies.

### (\*) [SCAN] Scanning Hotkey

In standby, press the [SCAN] key on the hand microphone to initiate a channel or frequency scan. In Frequency (VFO) mode, the radio will scan by the step frequency. In Channel (MR) mode, the radio will scan the channels programmed into it, starting from the current channel. Pressing the UP/DOWN keys while scanning will change the direction of the scan from low to high (UP) or high to low (DOWN). Press any key to stop the scan. Refer to MENU 9 (p 50) for more information on the types of scans available.

### Simultaneous Scanning on the A and B Areas

The A and B areas can perform a scan at the same time. To do this, press [SCAN] to activate the scan on the A Area, press [MAIN] to go to the B area, then press [SCAN] to activate the scan on B area. Both areas should scan simultaneously.

- When the PTT is pressed to transmit on the Primary Frequency Area during a

## Basic Operation

scan, the Secondary area will stop scanning temporarily. When the PTT is released at the end of transmission, scanning on the Secondary area will resume.

- During a scan, pressing the [SCAN] key will only stop the scan on the currently selected Area.
- Pressing the [VFO/MR] key will also stop the scan in the currently selected Area.

### Important!

While scanning the Secondary frequency area, some settings on the Primary frequency area will be prohibited. These include Save Channel (MEMCH), Scan Mode (SC-REV), Delete Channel (DEL-CH) and Channel Name Edit (CH-NAME) settings.

### (#) [LOCK] Keypad Lock Hotkey

When the radio is in standby, pressing the [LOCK] key locks the keypad from the primary frequency area. When the keypad is locked, all keys on the keypad of the hand

microphone and the front panel are locked, with an exception of the [BAND] key, which can switch to the secondary frequency area.

### **[ARROW UP] Up key**

In frequency mode, press the [UP] key to go to a higher frequency in the next higher frequency step.

In channel mode, press the [UP] key to go to the next higher channel.

### **[ARROW DOWN] Down key**

In frequency mode, press the [DOWN] key to go to a lower frequency in the next lower frequency step.

In channel mode, press the [DOWN] key to go to the next lower channel.

### **[MENU] Confirmation key**

Pressing this key enters the menu, selects menu options and saves them to the radio.

## **Menu Functions**

### **[1: STEP] Frequency Step**

Function: Allows you to adjust the steps between frequencies. Available only in VFO mode.

Options: 2.5K/5K/6.25K/10K/12.5K/20K/25K/30K/50K/100K

Default: 5K

### **[2: W/N] Bandwidth**

Function: Adjusts the bandwidth settings. The KG-1000M can operate on Wide (20kHz) or Narrow (11.25kHz) bandwidth.

Options: WIDE/NARR

Default: WIDE

### **[3: MPOWSET] Medium Power Level**

Function: Sets the medium level power setting to MPOW1 (1.0W) or MPOW2 (1.5W).

Options: MPOW-1/MPOW-2

Default: MPOW-1



### [4: ROGER] Roger Beep

Function: Enables an audible roger beep prompt during transmission.

Options: OFF/BOT/EOT/BOTH

Default: OFF

BOT: Sets the roger beep prompt at the beginning of transmission

EOT: Sets the roger beep at the end of transmission

BOTH: Sets the roger beep at the beginning and end of transmission

### [5: BEEP] Button Beeps

Function: Enables an audio prompt to alert the operator of a key press, input or fault.

Selectable: ON/OFF

Default: ON

### [6: VOICE] Voice Guide

Function: Enables or disables voice prompts.

Selectable: ON/OFF

Default: ON

## Menu Functions

### [7: BCL] Busy Channel Lockout

Function: Enabling Busy Channel Lockout prevents the transceiver from transmitting on a selected channel or frequency while another station or group is transmitting on it.

Options: ON/OFF

Default: ON

### [8: SP-MUTE] Speaker Mute Settings

Function: Speaker Mute settings

Options: QT/QT+DTMF/QT\*DTMF

Default: QT

QT: All signals on the same CTCSS tone/DCS code will activate the speaker

QT+DTMF: Only those signals which include both the same CTCSS/DCS and dual-tone multi-frequency (DTMF) signal as the radio will activate the speaker.

QT\*DTMF: Only those signals which have either the same QT or DTMF codes as the radio will activate the speaker.

### [9: SC-REV] Scan Method

Function: Scan mode settings

Options: TO/CO/SE

Default: SE

TO: When a signal is detected, scanning stops. Scanning will resume if no operation is carried out within 5 seconds.

CO: When a signal is detected, scanning stops and resumes 3 seconds after the signal is lost.

SE: When a signal is detected, scanning stops. Press the PTT key or function key to store it.

### [10: TOT] Transmit Overtime Timer

Function: When the transmission time exceeds the time set by the Timeout Timer, the unit will emit an error tone and stop transmitting within 10 seconds. The radio will not be able to transmit if the [PTT] is pressed, and will emit an error prompt. Transmit will be enabled again after 10 seconds.

Options: 1MIN-60MIN

Default: 2MIN

## **Menu Functions**

### **[11: TOA] Transmit Overtime Alarm**

Function: The Transmit Overtime Alarm warns when the transmit Timeout Timer (TOT) is about to be exceeded. The display screen flashes to indicate an alarm. The alarm can be set to a maximum time limit of 10 seconds.

Options: OFF/1S-10S

Default: 5S

### **[12: ANI-SW] Caller ID Transmit**

Function: When activated, the radio will transmit the 3-6 digit Caller ID specified in menu option 14.

Options: ON/OFF

Default: OFF

### **[13: RING] DTMF Prompt Time**

Function: Specifies the length of time to prompt when DTMF signals have been decoded.

Selectable: OFF/1S-10S

Default: 3S

### [14: ANI-EDIT] Caller ID Edit

Function: Sets the Caller ID. The caller ID is composed of numbers 0-9. The first digit cannot be 0. ID numbers must be at least 3 digits and a maximum of 6 digits.

Options: 0-9

Default: 101

### [15: DTMFST] Sidetone

Function: Activates the Caller ID and keypad sidetone during transmission.

Options: OFF/DT-ST/ANI-ST/DT+ANT

Default: DT/ST

DT-ST: Activates keypad sidetone

ANI-ST: Activates Caller ID sidetone

DT+ANT: Activates both keypad and Caller ID sidetones

### [16: PTT-ID] Caller ID Transmit Position

Function: Choose whether to transmit the ID at the beginning or end of transmission.

## Menu Functions

Options: BOT/EOT/BOTH

Default: BOT

BOT: Beginning of transmission

EOT: End of transmission

BOTH: Beginning and end of transmission

### [17: TX-LED] Transmit LED Color

Function: Selects the color of the LED indicator light during transmit.

Options: OFF/RED/ORG/GREEN

Default: RED

### [18: WT-LED] Standby LED Color

Function: Selects the color of the LED indicator light during Standby.

Options: OFF/RED/ORG/GREEN

Default: ORG

### [19: RX-LED] Receive LED Color

Function: Selects the color of the LED indicator light while receiving a signal.

Options: OFF/RED/ORG/GREEN

Default: GREEN

### [20: DEL-CH] Channel Delete

Function: Allows you to delete a channel from the radio. Select this menu option and use the UP/DOWN arrow keys to choose the channel you want to delete. Priority Channels are fixed channels and cannot be deleted.

Options: 999 channels

Default: CH-001

### [21: CH-NAME] Channel Name Edit

Function: Allows you to enter and edit the name for each channel. To edit a channel name, press the [UP] key to choose each character, press [DOWN] key to edit the next character, and press the [\*] to clear the character you are currently editing. Pressing the # key switches between special characters, numbers, upper, and lowercase letters. When you finish editing the name, press [MENU] to save it to the radio.

Note: Channel names can only be entered and edited in Channel Mode.

## Menu Functions

Options: 8 Characters

Default: None

### [22: PRICH-SW] Priority Channel On/Off

Function: Allows you to turn the priority channel function on or off. When enabled, the radio will scan the channel every 3 seconds.

Options: ON/OFF

Default: OFF

### [23: SPK-CONT] Speaker Select

Function: Selects the active speaker for the radio. The KG-1000M has three speakers. One is built into the hand microphone and two are built into the body of the radio.

Options: SPK1/SPK2/SPK1+2

Default: SPK1

SPK1: Activates the speakers in the base of the radio only

SPK2: Activates the speaker in the hand microphone only

SPK1+2: Activates all three speakers



### [24: AUTOLOCK] Auto Lock

Function: Automatically locks the buttons on the radio and hand microphone.

Options: ON/OFF

Default: OFF

### [25: RX-CTC] Receive CTCSS Tone

Function: Sets the receiving CTCSS tone for each channel. Use the arrow keys to select, or keypad to enter the tone. 50 standard tones are supported as well as non-standard tones. See page 69 to learn how to enter non-standard tones.

Options: OFF/standard CTCSS/Non-standard CTCSS

Default: OFF

### [26: RX-DCS] Receive DCS Tone

Function: Sets the receiving DCS code for each channel. Use the arrow keys to select your preferred code and then MENU to confirm. See page 69 to learn how to enter non-standard DCS codes.

Options: OFF/Standard negative & positive DCS/Non-standard DCS

## Menu Functions

Default: OFF

### [27: TX-CTC] Transmit CTCSS Tone

Function: Sets the transmit CTCSS tone for each channel. Use the arrow keys to select, or keypad to enter the tone. 50 standard tones are supported as well as non-standard tones. See page 69 to learn how to enter non-standard tones.

Options: OFF/Standard CTCSS/Non-standard CTCSS

Default: OFF

### [28: TX-DCS] Transmit DCS Tone

Function: Sets the transmit DCS code for each channel. Use the arrow keys to select your preferred code and then MENU to confirm. See page 69 to learn how to enter non-standard DCS codes.

Options: OFF/Standard negative & positive DCS/Non-standard DCS

Default: OFF

### [29: SCAN-ADD] Channel Scan Add / Delete

Function: Adds a channel to the list of channels to scan. Not available in VFO Mode.

Options: ON/OFF

Default: ON

### [30: APO-TIME] Power Off Timer

Function: The Automatic Power Off function automatically turns the radio off if it remains idle for a specified period of time.

Options: OFF/30MIN/60MIN/90MIN/120MIN/150MIN

Default: OFF

### [31: ALERT] Single Tone Pulse Transmission

Function: Activates the tone alert. Some relay systems used for single-tone pulse transmissions need a single-tone pulse signal to activate.

Options: 1000Hz/1450Hz /1750Hz/2100Hz

Default: 1750Hz

Special Reminder: When in transmit mode, you can send the single-tone pulse frequency you've selected by pressing the [MENU] key on the panel or the [MAIN] key on the microphone.

## Menu Functions

### [32: COMPAND] Comander

Function: The comander minimizes noise. Useful when transmitting over long distances.

Options: ON/OFF

Default: OFF

### [33: FAN-SET] Cooling Fan Settings

Function: The KG-1000M has a built-in temperature detection system that will activate a cooling fan as needed. There are three options.

Options: TX / HI-TE/TX / ALWAYS

Default: HI-TE/TX

TX: The fan turns on when transmitting

HI-TE/TX: The fan turns on when the temperature of the radio is high during transmit.

ALWAYS: The fan is always on.

### [34: LOW-V] Low Voltage Alert

**Function:** When enabled, the radio emits a voice prompt every 10 seconds when the voltage drops below an acceptable level. The radio will power off when voltage is too low for the unit to operate (9.5V-10.5V) and disable transmission if the voltage is too high.

**Note:** It is advisable to enable this function when the KG-1000M is installed in a car or connected to an unstable power source such as a vehicle battery.

**Options:** ON/OFF

**Default:** OFF

### [35: SCRAM] Descramble

**Function:** Activating this function will descramble incoming signals that are scrambled using one of 8 supported protocols.

**Options:** OFF/SCRAM 1-8

**Default:** OFF

### [36: SC-QT] CTCSS/DCS Scan Save Options

**Function:** This item determines how a CTCSS or DCS tone is saved after a CTCSS/DCS scan. There are three save options.

## Menu Functions

Options: DECODER/ENCODER/ALL

Default: DECODER

DECODER: Saves the scanned tone to the RX-CTC or RX-DCS setting

ENCODER: Saves the scanned tone to the TX-CTC or TX-DCS setting.

ALL: Saves the scanned tone to both.

### [37: SC-CTC] CTCSS Tone Scanning

Function: Scans the incoming signal for CTCSS tones to identify or confirm the correct tone. This can be useful when your CTCSS tone does not match the tone used by other members of your group, or to determine which tone they are using. This function must be activated while receiving a signal.

Options: None. Choose the function and press [MENU] to activate the scan.

Note: The scan will stop when the signal ends and resume from where it left off the next time the signal is received, until it identifies the correct tone. Use the [UP]/[DOWN] arrow keys or channel knob to make it scan in a different direction.

### [38: SC-DCS] DCS Tone Scanning

**Function:** Scans the incoming signal for DCS codes to identify or confirm the correct code. This can be useful when your DCS code does not match the code used by other members of your group, or to determine which code they are using. This function must be activated while receiving a signal.

**Options:** None. Choose the function and press [MENU] to activate the scan.

**Note:** The scan will stop when the signal ends and resume from where it left off the next time the signal is received, until it identifies the correct tone. Use the [UP]/[DOWN] arrow keys or channel knob to make it scan in a different direction.

### [39: SC-GROUP] Scan Group

**Function:** Categorizes the programmed channels into different scan groups. You can choose to scan one specific group or all groups. Not available in Repeater Mode.

**Options:** ALL/GROUP 01-10

**Default:** ALL

### [40: RPT-TONE] Repeater Reception Confirmation

## Menu Functions

Function: Provides a reception confirmation when the receiving repeater is offline.

Options: OFF/ON

Default: OFF

### [41: RESET] Factory Reset

Function: Resets the transceiver to factory defaults.

Options: VFO/ALL

Default: VFO

VFO: Resets only function settings to factory defaults. Channel data is not reset.

ALL: Resets all of the function settings and channel parameters to factory defaults.

### [42: KEY-A] Key "A" Assignment

Function: Assigns a function to the A key on the display panel

Options: OFF/B/SW/MENCH/ H/M/L/VFO/MR/TDR/SQL/SCAN/FM-RADIO/SC-CTC/SC-DCS

Default: FM RADIO

### [43: KEY-B] Key "B" Assignment



Function: Assigns a function to the B key on the display panel

Options: OFF/B/SW/MENCH/H/M/L/VFO/MR/TDR/SQL/SCAN/FM-RADIO/SC-CTC/SC-DCS

Default: SCAN

### [44: KEY-C] Key “C” Assignment

Function: Assigns a function to the C key on the display panel

Options: OFF/B/SW/MENCH/H/M/L/VFO/MR/TDR/SQL/SCAN/FM-RADIO/SC-CTC/SC-DCS

Default: TDR

### [45: ABR] Backlight

Function: Sets the timeout of the LCD display backlight while the radio is in standby. The timer can be set from 1-20 seconds in one second increments. It can also be set to turn off immediately or always remain on.

Options: OFF/ALWAYS/1-20S

Default: ALWAYS

## **Menu Functions**

### **[46: FM-RADIO] FM Radio**

Function: Enables the FM Radio. Only available on “Area A”.

Options: ON/OFF

Default: OFF

Note: To access the FM Radio, Press [MENU] on the front panel or hand microphone to begin the FM Radio scanning function. Press the lock key to activate the radio storage function, and press the lock key again to enter the radio channel menu. Press the [UP] and [DOWN] keys to choose the radio channel, then press [MENU] to confirm.

### **[47: AUT. AM] AM Detection**

Function: When activated, the KG-1000M will automatically recognize AM frequencies. Only available on “Area A”.

Options: ON/OFF

Default: ON

### **[48: AM-SW] AM On / Off**

Function: Enables or disables the reception of signals in AM mode. Only available on “Area A”.

Options: ON/OFF

Default: OFF

## Advanced Operation

### DTMF Encoding

The KG-1000M features dual-tone multi-frequency (DTMF) encoding. The number pad on the hand microphone corresponds to DTMF codes as follows:

MENU	▲	▼	EXIT	▶	AB		CD	
1 BAND	2 MHz	3 ET/DT	* SCAN	→	1	2	3	*
4 MEMCH	5 H/L	6 W/P/M	□ SCRAM	→	4	5	6	0
7 SET-D	8 TDR	9 SQL	# LOCK	→	7	8	9	#

Usage:

While pressing the [PTT] key to transmit, press the key on the hand microphone that corresponds to the DTMF tone that you wish to send.

## Setting Non-Standard CTCSS or DCS

### How to Set Non-Standard CTCSS

The KG-1000M supports non-standard CTCSS codes in the range of 65.0-255.0Hz with a minimum spacing of 0.1Hz.

After selecting the CTCSS menu setting (RX-CTC or TX-CTC), enter the desired CTCSS code via the keyboard and then press [MENU] to confirm.

For example, to set the receiving CTCSS tone to 100.5Hz:

In standby, press [MENU] + [2] + [5], the screen will display: RX-CTC, press MENU, and input [1] + [0] + [0] + [5], then press [MENU] to confirm, and [EXIT] to return to standby.

### How to Set Non-Standard DCS

The KG-1000M supports non-standard DCS codes ranging from 000-766, except any code with the digit 8 or 9. For example, 680.719 is not a legitimate non-standard DCS

## Advanced Operation

code.

After setting a non-standard DCS code, press the [LOCK] key to set it as a Positive or Negative code, or press the [SCAN] key to select OFF.

After selecting the DCS menu setting (RX-DCS or TX-DCS), enter the desired DCS code from the keypad on the hand microphone, press [LOCK] to select the Positive or Negative code, and then press MENU to confirm.

Example 1: Set the receive DCS as D105N

In standby, press [MENU] + [2] + [6] and the screen will display: RX-DCS. Press [MENU] and input [1] + [0] + [5], then press [LOCK] to select the Positive code. The screen will display D105N. Press [MENU] to confirm, and then press [LOCK] to return to standby.

Example 2: Set the receive DCS as D105I

In standby, press [MENU] + [2] + [6] and the screen will display: RX-DCS. Press [MENU] and input [1] + [0] + [5], then press [LOCK] to select the Negative code. The

screen will display D105I. Press [MENU] to confirm, and then press [EXIT] to return to standby.

## Troubleshooting

Before assuming your KG-1000M is defective, please check the following list of possible problems and solutions. Using the RESET option provided in the menu can also be used to reset the transceiver back to factory standard settings and programming.

Problem	Solution
Receive indicator is on but no sound is heard.	<ul style="list-style-type: none"><li>■ Check volume level.</li><li>■ Disable CTCSS/DCS or be sure setting matches incoming transmission.</li><li>■ Check squelch settings.</li></ul>
Keypad is unresponsive	<ul style="list-style-type: none"><li>■ Check if keypad has been locked.</li><li>■ Check if other keys are currently pressed</li></ul>
Unwanted interference is being received.	<ul style="list-style-type: none"><li>■ Enable CTCSS or DCS tone to filter out unwanted transmissions.</li><li>■ Use a different channel</li></ul>
Voice pause every 3 seconds	Check if the “PRICH-SW” (Priority scanning switch) is turned on.



Problem	Solution
Cannot activate Scan	Check if the scan group channel or Scan Add function is turned on.
Transceiver automatically shuts off	<ul style="list-style-type: none"> <li>■ Check if your power source is below 11.5 volts.</li> <li>■ Check if APO menu setting is activated.</li> </ul>
Transceiver does not transmit	Check if transceiver is tuned to a valid MURS frequency.

# Technical Information

## Specifications

General		Receiver	Wide bandwidth	Narrow bandwidth
Frequency Range	Frequency Range for US: RX: 50.000-53.995MHz & 108.000-179.995MHz 320.000-349.995MHz & 400.000-479.995MHz 700-985MHz TX: 151.820, 151.880, 151.940, 154.570 & 154.600 MHz (MURS Frequencies)	Adjacent Channel Selectivity	≤ 70dB	≤ 60dB
		Intermodulation	≤ 65dB	≤ 60dB
		Spurious Response	≤ 70dB	≤ 70dB
		Audio Response	+1~-3dB(0.3~3KHz)	+1~-3dB(0.3~2.55KHz)
Step Frequency	2.5KHz / 5KHz / 6.25KHz / 10KHz / 12.5KHz / 20KHz / 25KHz / 30KHz / 50KHz / 100KHz	Signal to Noise Ratio	≥ 45dB	≥ 40dB
Memory Channels	999	Audio Distortion	≤ 5%	
Work Mode	F2D / F3E	Audio Power	Transceiver ≤ 3W Hand Microphone ≤ 1W	
Operating Temperature	-20°C~+40°C	Sensitivity	400.000-479.995MHz:0.25uV(13dB SINAD) 136.000-174.995MHz:0.25uV(13dB SINAD) 50.000-53.995MHz:0.25uV(13dB SINAD) 320.000-349.995MHz:0.25uV(13dB SINAD) 700.000-985.995MHz:-97.0dBm(13dB SINAD)	
Antenna Impedance	50Ω			
Power Requirement	13.8VDC ± 15% (Negative Grounded)			
Weight	1437.8g (including microphone)			
Dimensions	140 x 44 x 207 (mm)			

Transmitter	Wide bandwidth	Narrow bandwidth	Transmitter	Wide bandwidth	Narrow bandwidth
Type of Modulation	16K F3E	11K F3E	Max. Frequency Deviation	± 5KHz	± 2.5KHz
Adjacent Channel Power	≥ 70dB	≥ 60dB	Frequency Stability	± 5ppm	
Spurious	≥ 60dB	≥ 60dB	Audio Distortion	≤ 5%	
Audio Response	+1~-3dB(0.3~3KHz)	+1~-3dB(0.3~2.55KHz)	Output Power	2W / 1.5W / 1W / 0.5W (MURS)	

## Standard CTCSS and DCS Tones

The following is a list of the standard CTCSS and DCS tones supported by the KG-1000M. Some MURS radios may display a number instead of a specific tone. The number to the left of the tone matches what is used by most manufacturers.

CTCSS									
1	67.0	11	94.8	21	131.8	31	171.3	41	203.5
2	69.3	12	97.4	22	136.5	32	173.8	42	206.5
3	71.9	13	100.0	23	141.3	33	177.3	43	210.7
4	74.4	14	103.5	24	146.2	34	179.9	44	218.1
5	77.0	15	107.2	25	151.4	35	183.5	45	225.7
6	79.7	16	110.9	26	156.7	36	186.2	46	229.1
7	82.5	17	114.8	27	159.8	37	189.9	47	233.6
8	85.4	18	118.8	28	162.2	38	192.8	48	241.8
9	88.5	19	123.0	29	165.5	39	196.6	49	250.3
10	91.5	20	127.3	30	167.9	40	199.5	50	254.1

## Technical Information

### DCS (positive code)

1	D023N	16	D074N	31	D165N	46	D261N	61	D356N	76	D462N	91	D627N
2	D025N	17	D114N	32	D172N	47	D263N	62	D364N	77	D464N	92	D631N
3	D026N	18	D115N	33	D174N	48	D265N	63	D365N	78	D465N	93	D632N
4	D031N	19	D116N	34	D205N	49	D266N	64	D371N	79	D466N	94	D645N
5	D032N	20	D122N	35	D212N	50	D271N	65	D411N	80	D503N	95	D654N
6	D036N	21	D125N	36	D223N	51	D274N	66	D412N	81	D506N	96	D662N
7	D043N	22	D131N	37	D225N	52	D306N	67	D413N	82	D516N	97	D664N
8	D047N	23	D132N	38	D226N	53	D311N	68	D423N	83	D523N	98	D703N
9	D051N	24	D134N	39	D243N	54	D315N	69	D431N	84	D526N	99	D712N
10	D053N	25	D143N	40	D244N	55	D325N	70	D432N	85	D532N	100	D723N
11	D054N	26	D145N	41	D245N	56	D331N	71	D445N	86	D546N	101	D731N
12	D065N	27	D152N	42	D246N	57	D332N	72	D446N	87	D565N	102	D732N
13	D071N	28	D155N	43	D251N	58	D343N	73	D452N	88	D606N	103	D734N
14	D072N	29	D156N	44	D252N	59	D346N	74	D454N	89	D612N	104	D743N
15	D073N	30	D162N	45	D255N	60	D351N	75	D455N	90	D624N	105	D754N

## Default MURS Channels and Frequencies

Ch.	Frequency	Max Power	Max Bandwidth	CH Name
1	154.5700	2 Watts	20.00 kHz	MURS-1
2	154.6000	2 Watts	20.00 kHz	MURS-2
3	151.8200	2 Watts	11.25 kHz	MURS-3
4	151.8800	2 Watts	11.25 kHz	MURS-4
5	151.9400	2 Watts	11.25 kHz	MURS-5

## Technical Information

### NOAA Weather Channels

Ch.	Frequency	Ch.	Frequency
1	162.4000	5	162.5000
2	162.4250	6	162.5250
3	162.4500	7	162.5500
4	162.4750		

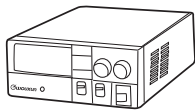

Switching Power  
Supply (30A)

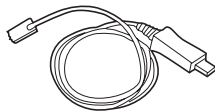

USB Programming  
Cable



Mobile  
Speaker / Mic



Omni-antenna

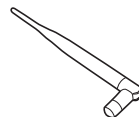

Omni-antenna



Directional-Antenna



Clamps Install  
Mount

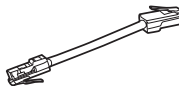

Connection Cable

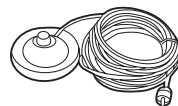

Strong Magnetic Mount

**Shop Wouxun Accessories:**

[www.buytwowayradios.com/accessories/by-radio-brand/wouxun-radio-accessories.html](http://www.buytwowayradios.com/accessories/by-radio-brand/wouxun-radio-accessories.html)

## Limited Warranty

We warrant this product against defects in material and workmanship as follows:

Radio and its original primary components for a period of one (1) year from date of purchase.

Accessories (including battery, charger, belt clip, antenna and adapter) for a period of six (6) months from date of purchase.

This warranty is limited to the repair and replacement of the defective components and is not valid if the radio has been tampered with, misused, abused, used with unapproved accessories, subjected to unauthorized disassembly, unauthorized repair, replacement of unauthorized parts, unavoidable conditions, human destruction, water damage or environmental damage. This warranty is void if the serial number is defaced or altered.

If service, repair or replacement is required within the warranty period, such repair or replacement will be made free of charge by the dealer through whom the equipment was purchased. If the owner requires any service or repair from any dealer through whom the equipment was not purchased, the cost of repair must be made by the owner.

This warranty is valid for the original purchaser or owner of the product and is not



transferable.

THIS LIMITED WARRANTY IS THE ENTIRE WARRANTY FOR THIS PRODUCT AND IS IN LIEU OF ALL OTHER WARRANTIES, EITHER EXPRESSED OR IMPLIED, INCLUDING ANY WARRANTY OF MERCHANTABILITY AND FITNESS FOR A PARTICULAR PURPOSE. THIS WARRANTY DOES NOT COVER OR PROVIDE FOR THE REIMBURSEMENT OR PAYMENT OF ANY DAMAGES, INCLUDING INCIDENTAL OR CONSEQUENTIAL DAMAGES RELATED TO THE USE OF THIS PRODUCT. Some states do not allow this exclusion or limitation of damages so the above limitation or exclusion may not apply to you. This warranty is valid only within the United States of America.

Note: Product features, specifications and warranty terms are subject to revision by the manufacturer without notice. We are not responsible for unintentional errors or omissions on product packaging.