

ICOM INSTRUCTIONS

UHF TRANSCEIVER IC-F200

Thank you for choosing this Icom product.
READ ALL INSTRUCTIONS carefully and completely before using this product.

IMPORTANT

SAVE THESE INSTRUCTIONS— These instructions contain basic operating instructions for the IC-F200 UHF TRANSCEIVER. The transceiver may have other functions and operations that are not described in this instruction manual. Ask your dealer for details.

Icom is not responsible for the destruction, damage to, or performance of any Icom or non-Icom equipment, if the malfunction is because of:

- Force majeure, including, but not limited to, fires, earthquakes, storms, floods, lightning, other natural disasters, disturbances, riots, war, or radioactive contamination.
- The use of Icom transceivers with any equipment that is not manufactured or approved by Icom.

Icom and the Icom logo are registered trademarks of Icom Incorporated (Japan) in Japan, the United States, the United Kingdom, Germany, France, Spain, Russia, Australia, New Zealand, and/or other countries. All other products or brands are registered trademarks or trademarks of their respective holders.

Icom Inc.

1-1-32 Kamiminami, Hirano-ku, Osaka 547-0003, Japan
Apr. 2023

A7725D-1EX-0a
Printed in Japan
© 2023 Icom Inc.

◇ Battery cautions

Misuse of Li-ion batteries may result in the following hazards: smoke, fire, or the battery may rupture. Misuse can also cause damage to the battery or degradation of battery performance.

⚠ DANGER! NEVER incinerate used battery packs. Internal battery gas may cause an explosion.

⚠ DANGER! NEVER strike or otherwise impact the battery pack. Do not use the battery pack if it has been severely impacted or dropped, or if the pack has been subjected to heavy pressure. Battery pack damage may not be visible on the outside of the case. Even if the surface of the battery does not show cracks or any other damage, the cells inside the battery may rupture or catch fire.

⚠ DANGER! NEVER leave the battery pack in places with temperatures above 60°C (140°F). High temperature buildup in the battery cells, such as could occur near fires or stoves, inside a sun-heated vehicle, or in direct sunlight for long periods of time may cause the battery cells to rupture or catch fire. Excessive temperatures may also degrade the battery pack's performance or shorten the battery cell's life.

⚠ DANGER! NEVER place battery packs near a fire. Fire or heat may cause them to rupture or explode. Dispose of used battery packs in accordance with local regulations.

⚠ DANGER! NEVER solder the battery terminals, or NEVER modify the battery pack. This may cause heat generation, and the battery may burst, emit smoke or catch fire.

⚠ DANGER! NEVER let fluid from inside the battery get in your eyes. This can cause blindness. Rinse your eyes with clean water, without rubbing them, and immediately go to a doctor.

⚠ WARNING! NEVER let fluid from inside the battery cells come in contact with your body. If it does, immediately wash with clean water.

⚠ WARNING! NEVER put the battery pack in a microwave oven, high-pressure container, or in an induction heating cooker. This could cause a fire, overheating, or cause the battery cells to rupture.

⚠ WARNING! NEVER use deteriorated battery packs. They could cause a fire.

CAUTION: DO NOT use the battery pack out of the specified temperature range, -20°C ~ +60°C (-4°F ~ +140°F). Using the battery out of its specified temperature range will reduce its performance and battery cell's life.

CAUTION: DO NOT leave the pack fully charged, completely discharged, or in an excessive temperature environment (above 50°C, 122°F) for an extended period of time. If the battery pack must be left unused for a long time, it must be detached from the transceiver after discharging. You may use the battery pack until the remaining capacity is about half, then keep it safely in a cool and dry place at the following temperature range:

-20°C ~ +50°C (-4°F ~ +122°F) (within a month)
-20°C ~ +40°C (-4°F ~ +104°F) (within three months)
-20°C ~ +20°C (-4°F ~ +68°F) (within a year)

FCC INFORMATION

This equipment has been tested and found to comply with the limits for a Class B digital device, pursuant to part 15 of the FCC Rules. These limits are designed to provide reasonable protection against harmful interference in a residential installation. This equipment generates, uses and can radiate radio frequency energy and, if not installed and used in accordance with the instructions, may cause harmful interference to radio communications. However, there is no guarantee that interference will not occur in a particular installation. If this equipment does cause harmful interference to radio or television reception, which can be determined by turning the equipment off and on, the user is encouraged to try to correct the interference by one or more of the following measures:

- Reorient or relocate the receiving antenna.
- Increase the separation between the equipment and receiver.
- Connect the equipment into an outlet on a circuit different from that to which the receiver is connected.
- Consult the dealer or an experienced radio/TV technician for help.

CAUTION: Changes or modifications to this transceiver, not expressly approved by Icom Inc., could void your authority to operate this transceiver under FCC regulations.

This device complies with Part 15 of the FCC Rules. Operation is subject to the condition that this device does not cause harmful interference.

ABOUT WELD LINES

This product's surfaces may have streaks called "weld lines," that occur during the molding process, and are not cracks or flaws.

EXPLICIT DEFINITIONS

WORD	DEFINITION
⚠ DANGER!	Personal death, serious injury or an explosion may occur.
⚠ WARNING!	Personal injury, fire hazard or electric shock may occur.
CAUTION	Equipment damage may occur.
NOTE	If disregarded, inconvenience only. No risk of personal injury, fire or electric shock.

PRECAUTIONS

⚠ DANGER! NEVER operate the transceiver near unshielded electrical blasting caps or in an explosive atmosphere. This could cause an explosion and death.

⚠ WARNING! NEVER use or charge Icom battery packs with non-Icom transceivers or non-Icom chargers. Only Icom battery packs are tested and approved for use with Icom transceivers or charged with Icom chargers. Using third-party or counterfeit battery packs or chargers may cause smoke, fire, or cause the battery to burst.

⚠ WARNING RF EXPOSURE! This transceiver emits Radio Frequency (RF) energy. Extreme caution should be observed when operating this transceiver. If you have any questions regarding RF exposure and safety standards, please refer to the Federal Communications Commission Office of Engineering and Technology's report on Evaluating Compliance with FCC Guidelines for Human Radio Frequency Electromagnetic Fields (OET Bulletin 65).

⚠ WARNING! NEVER hold the transceiver so that the antenna is very close to, or touching exposed parts of the body, especially the face or eyes, while transmitting.

⚠ WARNING! NEVER operate or touch the transceiver with wet hands. This could cause an electric shock or damage the transceiver.

⚠ WARNING! NEVER operate the transceiver with earphones, a headset or other audio accessories at high volume levels. The continuous high volume operation may cause a ringing in your ears. If you experience the ringing in your ears, reduce a volume level or discontinue use.

CAUTION: DO NOT use or leave the transceiver in excessively dusty environments. This could damage the transceiver.

CAUTION: DO NOT short the terminals of the battery pack. Shorting may occur if the terminals touch metal objects such as a key, so be careful when placing the battery packs (or the transceiver) in bags, and so on. Carry them so that shorting cannot occur with metal objects. Shorting may damage not only the battery pack but also the transceiver.

CAUTION: DO NOT change the internal settings of the equipment. This may reduce equipment performance and/or cause extensive and expensive damage to the equipment. The equipment warranty does not cover any problems caused by unauthorized internal adjustments.

SAFETY TRAINING INFORMATION



Your Icom radio generates RF electromagnetic energy while transmitting. This radio is designed for and classified as for "Occupational Use Only." This means it must be used only during the course of employment by individuals aware of the hazards, and the ways to minimize such hazards. This radio is NOT intended for use by the "General Population" in an uncontrolled environment. This radio has been tested and complies with the FCC RF exposure limits for "Occupational Use Only". In addition, your Icom radio complies with the following Standards and Guidelines with regard to RF energy and electromagnetic energy levels and evaluation of such levels for exposure to humans:

- FCC KDB Publication 447498 D03, Evaluating Compliance with FCC Guidelines for Human Exposure to Radio Frequency Electromagnetic Fields.
- American National Standards Institute (C95.1-2019), IEEE Standard for Safety Levels with Respect to Human Exposure to Electric, Magnetic, and Electromagnetic Fields, 0 Hz to 300 GHz
- American National Standards Institute (C95.3-2021), IEEE Recommended Practice for Measurements and Computations of Electric, Magnetic, and Electromagnetic Fields with Respect to Human Exposure to Such Fields, 0 Hz to 300 GHz
- The batteries, belt clips, speaker-microphone, and other accessories that are listed in "OPTIONS" on this sheet, are authorized for use with this product. Use of accessories other than those specified may result in RF exposure levels exceeding the FCC requirements for wireless RF exposure.
- Health Canada Safety Code 6 - Limits of Human Exposure to Electromagnetic Energy in the Frequency Range from 3 kHz to 300 GHz.

CAUTION: DO NOT operate the transceiver unless the rear cover and the connector covers are securely attached to the transceiver and that the battery pack are dry before attachment.

Exposing the inside of the transceiver to dust or water will result in serious damage to the transceiver.

CAUTION: DO NOT operate the transceiver while driving a vehicle. Safe driving requires your full attention— anything less may result in an accident.

CAUTION: DO NOT use harsh solvents such as Benzine or alcohol when cleaning. This could damage the equipment surfaces. If the surface becomes dusty or dirty, wipe it clean with a soft, dry cloth.

CAUTION: DO NOT use the non-specified microphone. Other microphones have different pin assignments and may damage the transceiver.

CAUTION: Confirm that all connectors and jacks are dry and clean before attachment. Exposing them to dust or water will result in serious damage to the transceiver.

NOTE: DO NOT use or leave the transceiver in areas with temperatures below -20°C (-4°F) or above +60°C (+140°F), or in areas subject to direct sunlight, such as the dashboard.

DO NOT push PTT unless you actually intend to transmit.

NEVER place the transceiver in an insecure place to avoid inadvertent use by unauthorized persons.

Even when the transceiver power is OFF, a slight current still flows in the circuits. Remove the battery pack from the transceiver when not using it for a long time. Otherwise, the installed battery pack will become exhausted, and will need to be recharged or replaced.

KEEP the transceiver away from heavy rain, and never immerse it in water. The transceiver meets IP54* requirements for dust-protection and splash resistance. However, once the transceiver has been dropped, or the waterproof seal is cracked or damaged, dust-protection and splash resistance cannot be guaranteed due to the fact that the transceiver may be cracked or the waterproof seal damaged, and so on.

* Only when the rear cover and the connector covers are attached.

NOTE: When an optional product with a lower IP rating than the transceiver is attached, the transceiver meets the lower IP rating of the optional product.



To ensure that your exposure to RF electromagnetic energy is within the FCC allowable limits for occupational use, always adhere to the following guidelines:

- **DO NOT** transmit for more than 50% of the total radio use time ("50% duty cycle"). Transmitting more than 50% of the time can cause FCC RF exposure compliance requirements to be exceeded. The radio is transmitting when the "TX" indicator is displayed. You can cause the radio to transmit by pushing the "PTT" switch.
- **ALWAYS** keep the antenna at least 2.5 cm (1 inch) away from the body when transmitting, and only use the Icom belt-clips listed in "OPTIONS" on this sheet when attaching the radio to your belt, or other place, to ensure FCC RF exposure compliance requirements are not exceeded. The information listed above provides the user with the information needed to make him or her aware of RF exposure, and what to do to assure that this radio operates within the FCC RF exposure limits of this radio.
- **Electromagnetic Interference/Compatibility** During transmissions, your Icom radio generates RF energy that can possibly cause interference with other devices or systems. To avoid such interference, turn off the radio in areas where signs are posted to do so. DO NOT operate the transmitter in areas that are sensitive to electromagnetic radiation such as hospitals, aircraft, and blasting sites.
- **Occupational/Controlled Use** The radio transmitter is used in situations in which persons are exposed as a consequence of their employment, provided those persons are fully aware of the potential for exposure and can exercise control over their exposure.

SUPPLIED ACCESSORIES

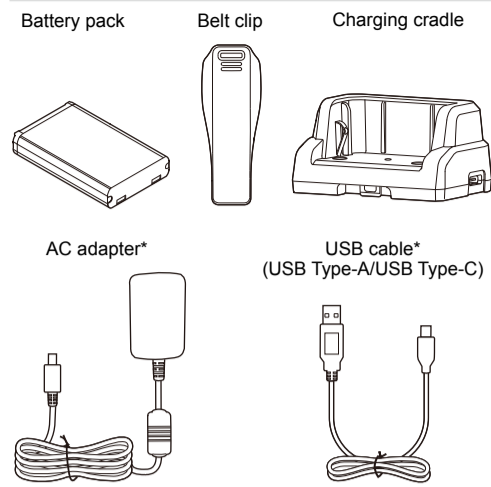

* Either one is supplied.

NOTE: Some accessories are not supplied, or the shape is different, depending on the transceiver version.

◇ Belt clip

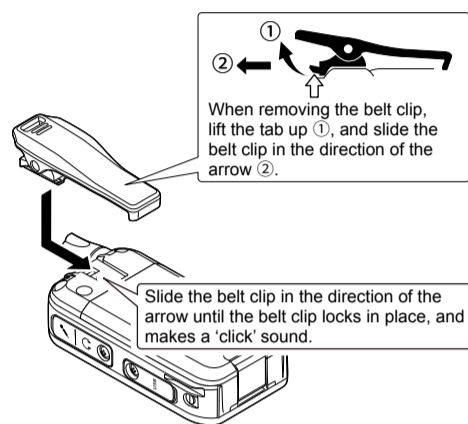

BE CAREFUL! DO NOT break your fingernail.

TIP: When attaching a hand strap (User supplied)

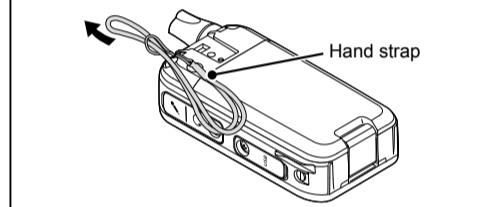

◇ Battery pack

NOTE: Before detaching or attaching a battery pack, **BE SURE** to turn OFF the transceiver by holding down [⏻] for 1 second. Otherwise, a transceiver malfunction could occur.

1. Release the rear cover lock clip (1) and remove the rear cover (2).

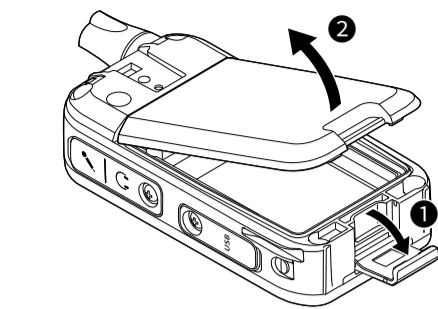

2. Install the supplied battery pack so that the terminals of the battery pack and the transceiver meet.

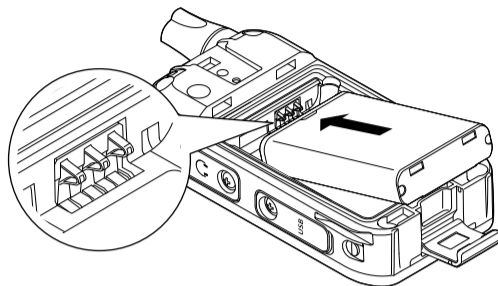

3. Replace the rear cover (1) and the rear cover lock clip (2).

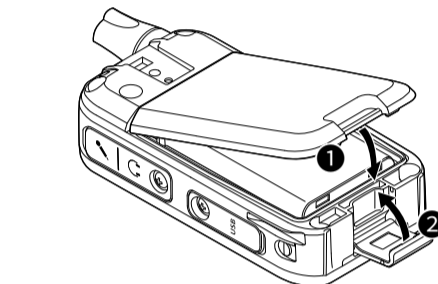

TIP: To remove the battery pack, slide the battery pack and lift it.

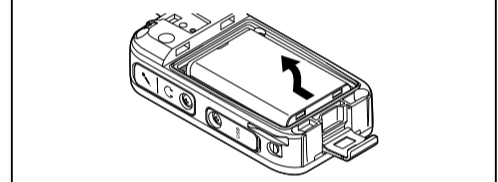

BATTERY CHARGING

- Fully charge the transceiver before using it for the first time, or if it has not been used for more than 2 months. The charger automatically restarts charging when the battery voltage drops.
- Disconnect the AC adapter or the USB cable from the outlet when the charger is not in use.
- Use the supplied AC adapter or the USB cable.
- The battery icon on the function display blinks while charging and lights when the charging has been completed.

◇ Charging directly

Connect the supplied AC adapter or USB cable to the [USB] Connector.
Charging time with the BC-263A: Approximately 5.5 hours

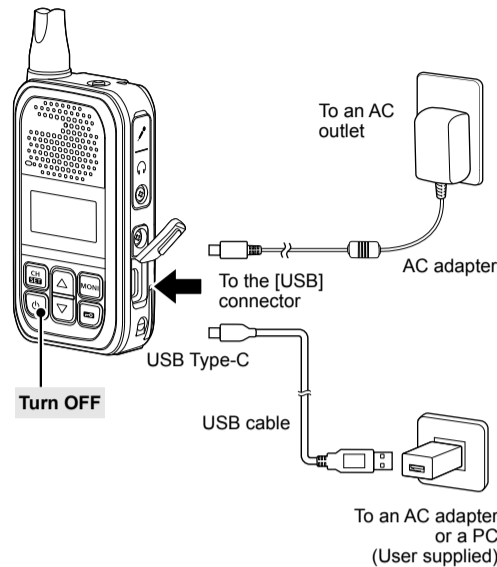

NOTE for charging with a USB cable:

- Not support USB Power Delivery (USB PD).
- The charging time may differ, depending on the current. When you use a lower than 1 A output AC adapter or PC, it may take longer to charge, or the battery may not be charged.
- Before using the AC adapter, thoroughly read its instructions.

NOTE: If "Q ER" is displayed, a charging error has occurred.

- Disconnect the USB cable or AC adapter, and then connect properly.
- Properly attach the battery pack to the transceiver.
- Properly insert the transceiver into the charging cradle.
- Charge the battery pack within the specified temperature range: 15°C ~ 40°C (59°F ~ 104°F).

◇ Charging on the cradle

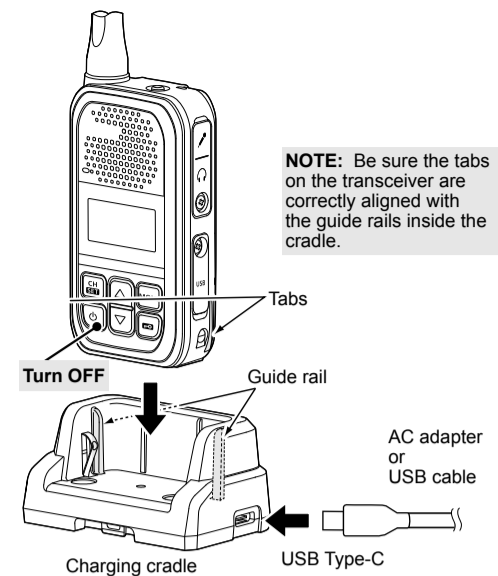

◇ Rapidly charging the battery pack

You can charge the battery pack with the optional BC-264 BATTERY CHARGER. Install the supplied battery pack so that the terminals of the battery pack and the battery charger meet.

① The battery pack can be charged by the charging cradle with BC-262 inserted.

Charging time with the BC-263A: Approximately 3.8 hours

NOTE: Charging time will be longer in extremely hot or cold environments. We recommend charging at 15°C ~ 40°C (59°F ~ 104°F).

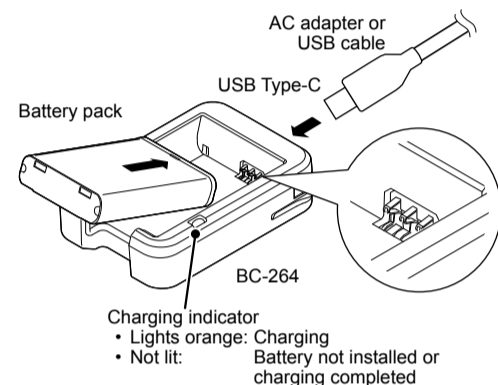

NOTE for charging with a USB cable:

- Not support USB Power Delivery (USB PD).
- The charging time may differ, depending on the current. When you use a lower than 1 A output AC adapter or PC, it may take longer to charge, or the battery may not be charged.
- Before using the AC adapter, thoroughly read its instructions.

PANEL DESCRIPTION

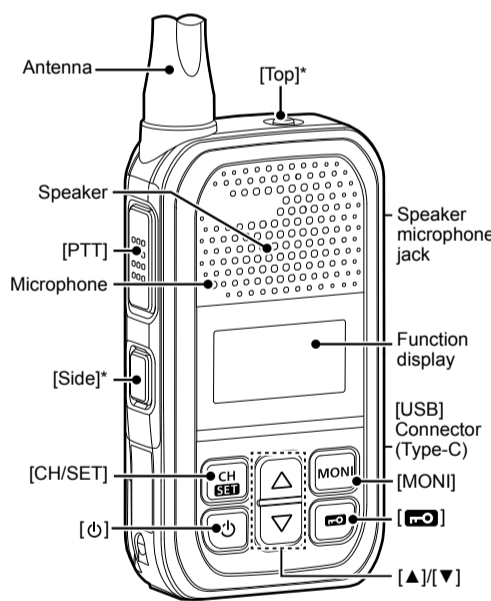

* The [Side] and [Top] key functions are dealer assignable.

◇ Operating keys

[PTT] switch
Hold down to transmit, release to receive.

[⏻] key
Hold down for 1 second to turn the transceiver ON or OFF.

[CH/SET] key

- On the Standby screen, push to enter or exit the Channel Select mode.
- On the Standby screen, hold down for 1 second to enter the Set mode.
- In the Set mode, push to move between the setting items, and hold down for 1 second to return to the Standby screen.

[▲]/[▼] key

- In the Standby screen, push to adjust the audio level.
- In the Set mode and the Channel Select mode, push to select a value.

[MONI] key
While holding down this key, the Monitor function is ON in the Standby screen.

[⏻] key
In the Standby screen, hold down for 1 second to turn the Lock function ON or OFF.

◇ Function Display

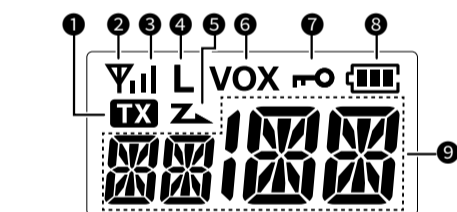

- 1 **TX ICON TX**
Displayed while transmitting.
- 2 **ANTENNA ICON ▽**
 - Displayed while the channel is busy (receiving).
 - Blinks while the monitor function is turned ON.
- 3 **SIGNAL STRENGTH INDICATOR**
Displays the relative receive signal strength level.
- 4 **LOW POWER ICON L**
Displayed when the low output power is selected.
- 5 **SCAN ICON Z**
 - Displayed when the channel is selected as a scan target channel.
 - Blinks while scanning.
- 6 **VOX ICON VOX**
Displayed when the VOX function is ON.
- 7 **KEY LOCK ICON**
Displayed when the Key Lock function is ON.
- 8 **BATTERY INDICATOR**
 - Blinks while charging.
 - Displays the remaining battery charge.

Indication				
Battery Status	Full	Mid	Charging required	Battery exhausted

*Blinks when the battery charge decreases to a set level.

- 9 **ALPHANUMERIC READOUT**
Displays messages such as channel number.

◇ Connectors

SPEAKER MICROPHONE JACK
To connect an optional speaker microphone or headset.

USB CONNECTOR
For only charging the battery.
① The USB connector does not support USB Power Delivery (USB PD) or a data communication.

CAUTION: DO NOT use the transceiver without the connector covers or the optional equipment attached. The transceiver meets IP54 requirements for dust-tight and splash resistance only when the connector covers or the optional HM-183LS is attached.

BASIC OPERATION

◇ Turning the transceiver ON or OFF

NOTE: Before using the transceiver for the first time, the battery pack must be fully charged for optimum life and operation. See the BATTERY CHARGING section.

- Hold down [⏻] for 1 second to turn the transceiver ON or OFF.

◇ Adjusting the audio volume

- On the Standby screen, push [▲] or [▼] to adjust the audio volume.
- ① The volume can be adjusted between 0 and 32.

◇ Selecting a channel

1. On the Standby screen, push [CH/SET].
 - Enters the Channel Select mode and the channel number blinks.
2. Push [▲] or [▼] to select a channel, and then push [CH/SET] to apply the setting.
 - Returns to the Standby screen.

◇ Receiving and Transmitting

- Receiving:**
- When a call is received, the antenna icon is displayed.
 - Push [▲] or [▼] to adjust the audio output level to a comfortable listening level.
- Transmitting:**
- While holding down [PTT], speak at your normal voice level.
 - The "TX" icon is displayed while [PTT] is held down.

IMPORTANT:
To maximize the readability of your signal:

1. After pushing [PTT], pause briefly before you start speaking.
2. Hold the microphone 5 ~ 10 cm (2 ~ 4 inches) from your mouth, then speak at your normal voice level.

◇ Set mode operation

NOTE: The Set mode items contained in the transceiver may differ, depending on the transceiver version or presetting. Ask your dealer for details.

1. On the Standby screen, hold down [CH/SET] for 1 second.
 - Enters the Set mode.
2. Push [CH/SET] several times to select a setting item, and then push [▲] or [▼] to select a value.
3. Hold down [CH/SET] for 1 second to exit the Set mode.
 - Returns to the Standby screen.

◇ Key Lock function

You can use the Key Lock function to prevent accidental channel changes and unnecessary function access, depending on the presetting.

All assignable keys except the following are electronically locked: [MONI], [Volume Up], [Volume Down], [EMERGENCY], [Surveillance], and [PTT]. You can also make or receive calls, or turn the transceiver ON or OFF, during the Key Lock function is ON.

- Hold down [⏻] for 1 second to turn the Key Lock function ON or OFF.
 - The "LO" icon is displayed when the Key Lock function is ON.

OPTIONS

◇ Battery pack

- **BP-304A:** Li-ion BATTERY PACK 3.6 V, 2200 mAh (minimum), 2350 mAh (typical)

◇ Belt Clip

- **MB-127** BELT CLIP

◇ Chargers

- **BC-262** BATTERY CHARGING CRADLE
- **BC-264** BATTERY CHARGER
- **BC-263A** AC ADAPTER
- ① BC-263A AC ADAPTER is available only in the USA.

◇ Speaker-Microphones

- **HM-183LS, HM-186LS** SPEAKER MICROPHONE

◇ Earphone microphones and Headsets

- **HM-153LS, HM-166LS** EARPHONE MICROPHONE
- **HS-94** HEADSET (Ear hook type)
- **HS-95** HEADSET (Neck and arm type)
- **HS-97** HEADSET (Throat microphone)

◇ Others

- **OPC-2006LS** PLUG ADAPTER CABLE L-type plug conversion cable Connects the HS-94/HS-95/HS-97 to the transceiver for the VOX operation.
- **OPC-2328** PTT SWITCH CABLE L-type headset adapter cable with PTT switch Connects the HS-94/HS-95/HS-97 to the transceiver.
- **OPC-2144** PLUG ADAPTER CABLE L-type plug conversion cable Connects the optional speaker microphone, earphone microphone, or headset to the transceiver.

NOTE: BE SURE to turn OFF the transceiver before connecting or disconnecting an optional equipment.

① Some options may not be available in some countries. Ask your dealer for details.