

Thank you for purchasing the MB-130 VEHICLE CHARGER BRACKET. The MB-130 is designed to mount an Icom battery charger in your vehicle.

Please read these instructions thoroughly before mounting your MB-130.

## PRECAUTIONS

**DO NOT** use or place the vehicle charger bracket in direct sunlight, or in areas outside of the temperature range which is specified for the battery charger you will use.

**DO NOT** use harsh solvents such as benzine or alcohol to clean the vehicle charger bracket, because they can damage the bracket's surfaces.

Securely connect the DC power cable or cigarette lighter cable before charging.

## MOUNTABLE CHARGERS

(chargeable temperature range)

- **BC-160** (0°C to 45°C; 32°F to 113°F)
- **BC-190** (10°C to 40°C; 50°F to 104°F)
- **BC-191** (10°C to 40°C; 50°F to 104°F)
- **BC-192** (0°C to 45°C; 32°F to 113°F)
- **BC-193** (10°C to 40°C; 50°F to 104°F)

## SUPPLIED ITEMS

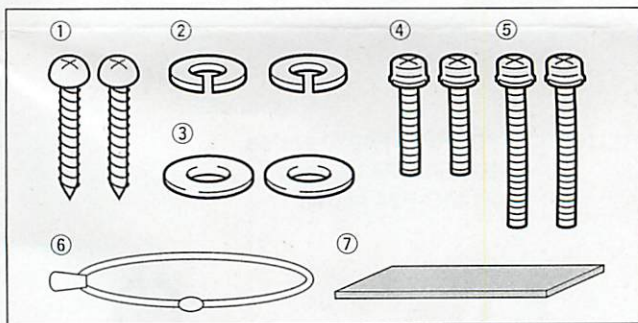

Qty.

|                                   |       |   |
|-----------------------------------|-------|---|
| ① Self tapping screws (A0 4 × 20) | ..... | 2 |
| ② Spring washers (M4)             | ..... | 2 |
| ③ Flat washers (M4)               | ..... | 2 |
| ④ Set screws (M3 × 15)            | ..... | 2 |
| ⑤ Set screws (M3 × 20)            | ..... | 2 |
| ⑥ Elastic cord                    | ..... | 1 |
| ⑦ Sponge                          | ..... | 1 |

## MOUNTING

- ① Securely mount the vehicle charger bracket to a thick surface, using the two A0 4 × 20 screws, spring washers and flat washers.

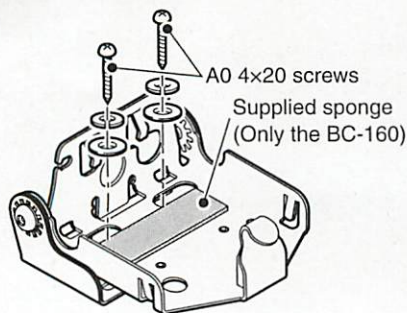

### For Only the BC-160:

Attach the supplied sponge onto the bracket, as shown above.

- ② Attach the supplied elastic cord.
  - See the back page for details.
  - Make sure to position the clip on the elastic cord so it will not touch the charger
- ③ Place the charger on the bracket.
- ④ Attach the charger with the supplied set screws.
  - For the BC-160, no screws are necessary to attach the charger. Go to the next step.
  - For the BC-190, use the M3 × 15 set screws.
  - For the BC-191, BC-192 or BC-193, use the M3 × 20 set screws.

- ⑤ Loosen the socket bolts on both sides of the bracket, then adjust the angle, if desired.
  - Use a 3 mm allen wrench. (Purchase locally.)
  - Tighten the bolts after adjusting.
- ⑥ Connect a DC power cable or cigarette lighter cable to the charger's DC jack.
- ⑦ Charge a battery pack with or without a transceiver, as described in the transceiver's instruction manual.
  - Hold down the transceiver or battery pack using the elastic cord. (see the back page.)

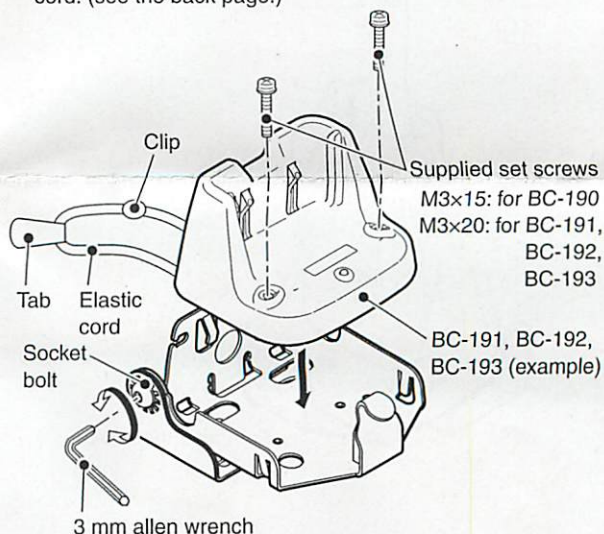

# ELASTIC CORD ATTACHMENT

• BC-160 + IC-F3060/IC-F4060 series

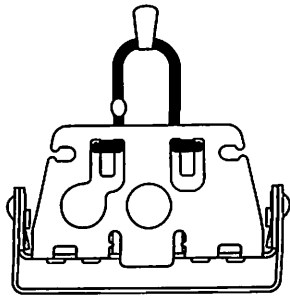

Rear view

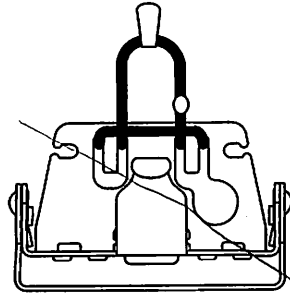

Front view

• BC-190 + IC-F50/IC-F60 series

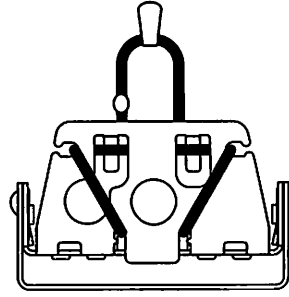

Rear view

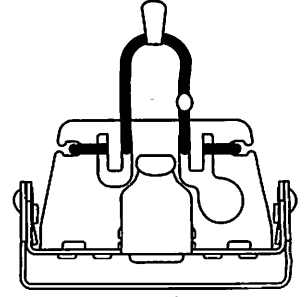

Front view

• BC-160 + IC-F3020/IC-F4020 series,  
IC-F33G/IC-F43G series,  
IC-F14/IC-F24 series

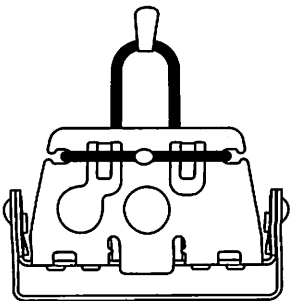

Rear view

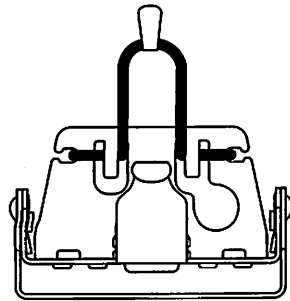

Front view

• BC-191/BC-192/BC-193 + IC-F3000/IC-F4000 series,  
IC-F3100/IC-F4100

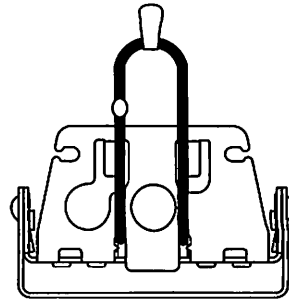

Rear view

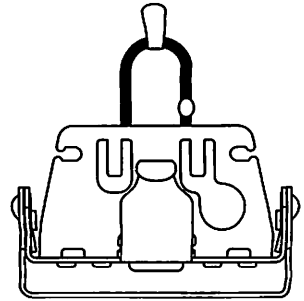

Front view

## About elastic cord:

While charging, put the tab under the hook to securely hold down the transceiver.

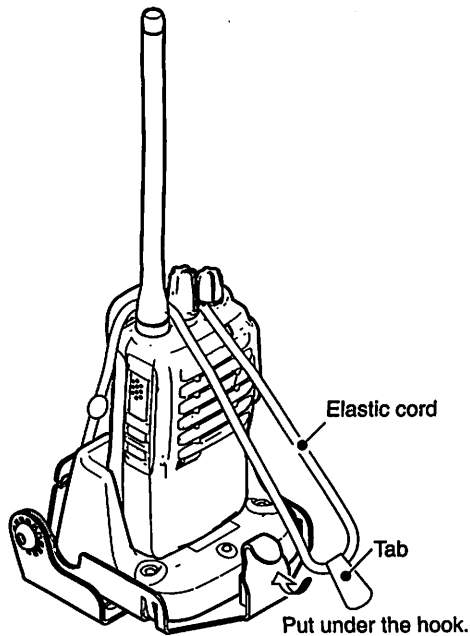

Icom, Icom Inc. and the Icom logo are registered trademarks of Icom Incorporated (Japan) in Japan, the United States, the United Kingdom, Germany, France, Spain, Russia and/or other countries.

**Icom Inc.**

1-1-32 Kamiminami, Hirano-ku, Osaka 547-0003, Japan

**Count on us!**

A-7015H-1EX Printed in Japan  
© 2012 Icom Inc.